

VSmk2 Disc Brake Caliper - Spring Applied, Hydraulically Released

See Publication Ref. No.M1128 Installation, Operation and Maintenance.

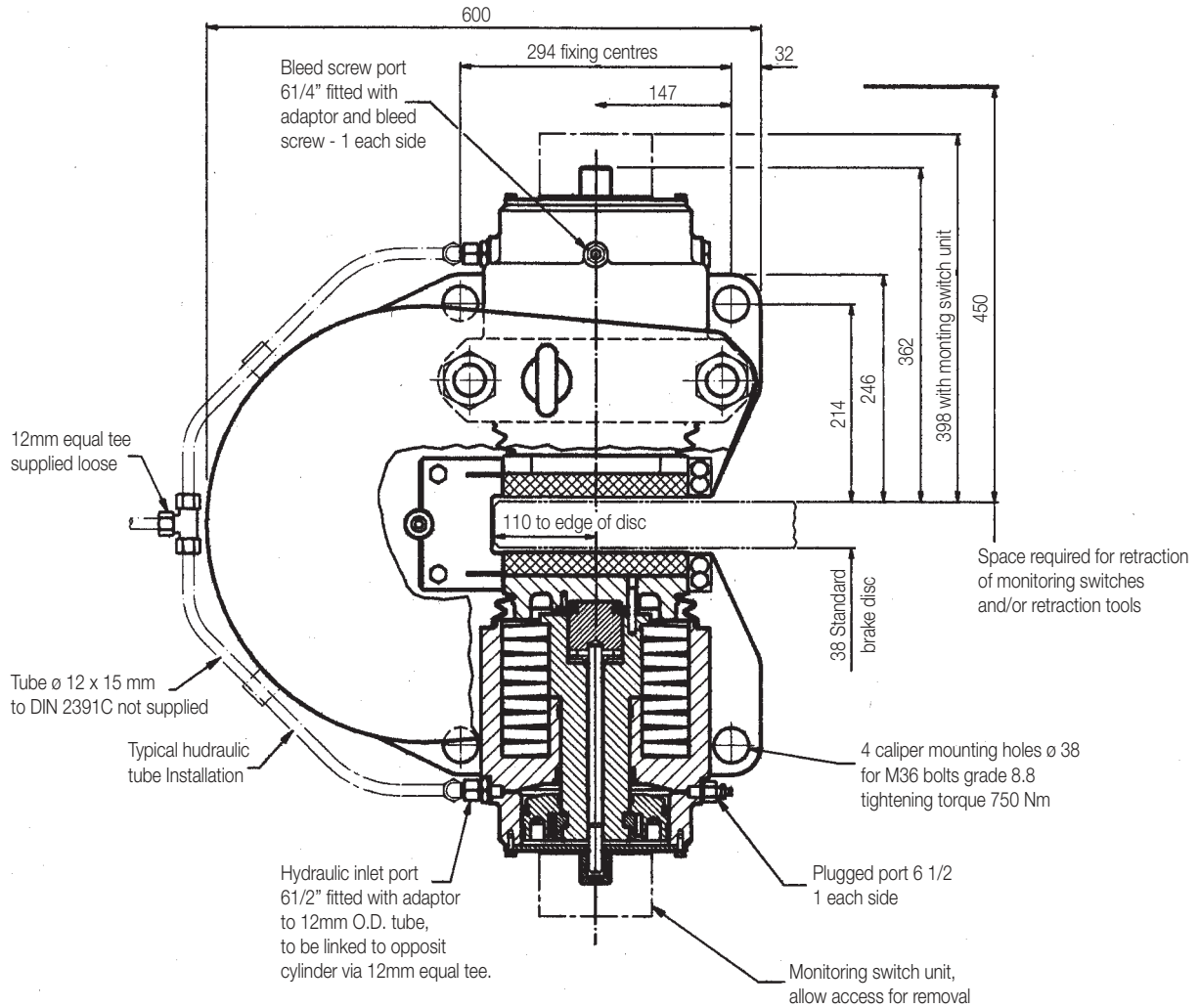

Caliper weight 400kg approx.

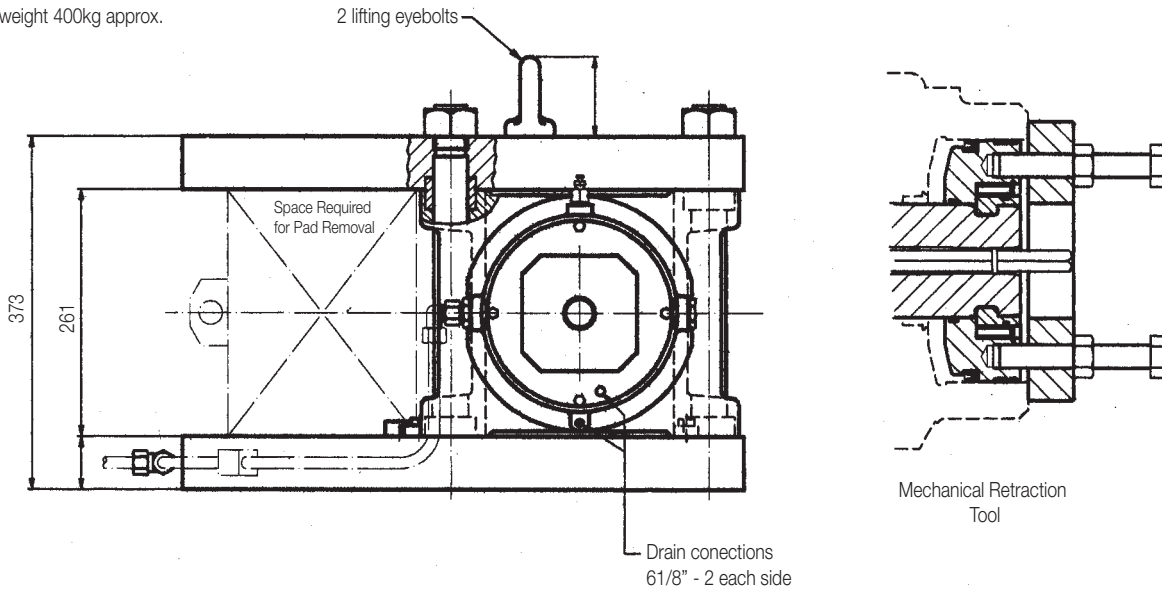

VSmk2 Disc Brake Caliper - Spring **TEKMATIC** Hydraulically Released

Distribuidor exclusivo para la República Argentina
 T. 011 4222 5040 - F. 011 4201 2478
 www.tekmatic.com.ar - info@tekmatic.com.ar

Technical Data:

BRAKE DISC

- Diameter - 800 minimum. There is no maximum limit except for practical considerations
- Thickness - 38mm minimum. There is no maximum limit except for practical considerations
- Material - standard discs sg iron to BS 2789 grade 420/12. (Twiflex data sheet DB 5002)
- Finish - brake path surface to be 2µm or better.

BRAKE PADS	Length	Width	Thickness	Area(2 pads)	Wear Allowance
	260mm	200mm	25mm	1039cm ²	13mm

HYDRAULICS

The recommended fluid is mineral oil based hydraulic fluid. Correctly formulated water-in-oil emulsions may also be used. Fluid displacement for 1 mm retraction at both pads - 32ml. Brake fill volume 400ml.

BRAKE ADJUSTMENTS

The adjusting spindle sets the air between brake pad and brake disc and allows brake pad wear to be taken up in a high wear situation, re-setting should be frequent. Monitoring units are optionally available to indicate a) brake off, b) wear adjustment required and c) pad replacement required.

MECHANICAL RETRACTION

A tool is provided, fitted to each spring module to enable mechanical retraction. This assists initial installation and may be used in the event of hydraulic system failure. It is the safer means of retraction when replacing brake pads.

Performance Data:

Caliper Type	Braking Force kN	Pressure to Release Brake bar	Pressure for Full Retraction bar	Braking force assumes - a) a coefficient of friction between brake pad and brake disc of 0.4* b) a loss of 2% due to spring pack friction. c) an air gap setting of 4mm. Braking force is increased by 7.8kN for each 1 mm reduction in air gap setting and vice versa. Pressure allow for 3% loss due to seal friction. Maximum allowable pressure 200 bar. * This is only achieved by fully bedded-in and conditioned brake pads and a high standard of cleanliness and dryness at the friction surfaces. A bedding-in procedure is available in publication M1065. An appropriate service factor should be applied according to the duty. In the case of holding brakes or wet conditions this should be at least 2.
VS 230	185	155	180	
VS 205	165	138	163	
VS 190	153	128	154	
VS 175	141	110	144	
VS 155	125	105	131	
VS 137	111	92	108	
VS 100	81	68	84	

Braking Torque

Braking Torque (Tb) = Braking Force (Fb)
 x Effective Disc Radius (Re)
 Effective Disc Radius (Re) = Actual Disc Radius (R) - 0.11 m
 $Tb = Fb \times Re$ (Re = R - 0.11 m)
 $Tb = Fb(R - 0.11) \text{ Nm}$
 For Tb in lbf ft, apply Fb in lbf and R in ft
 $Tb = Fb(R - 0.36ft) \text{ lbf ft}$

Twiflex disc brakes must be used with Twiflex asbestos free pads. The use of any other brake pad will invalidate the warranty. Twiflex Limited reserves the right to modify or change the design without prior notice. This document is the intellectual property of Twiflex Limited.



An Altra Industrial Motion Company

www.twiflex.com

9 Briar Road, Twickenham
 Middlesex TW2 6RB - England
 +44 (0) 20 8894 1161
 Fax: +44 (0) 20 8755 5601



This approval is in Accordance with
 Certificate number 850822
 Issue 04 June 2009 © Twiflex 2001.

DB2018 11/11 Printed in USA